

To avoid injury, read user's manual before using.

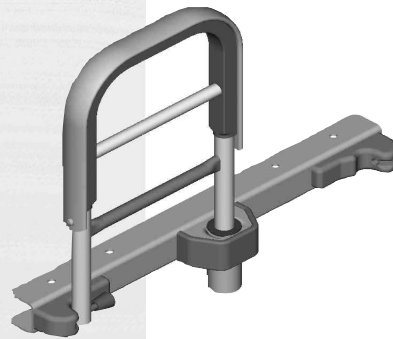
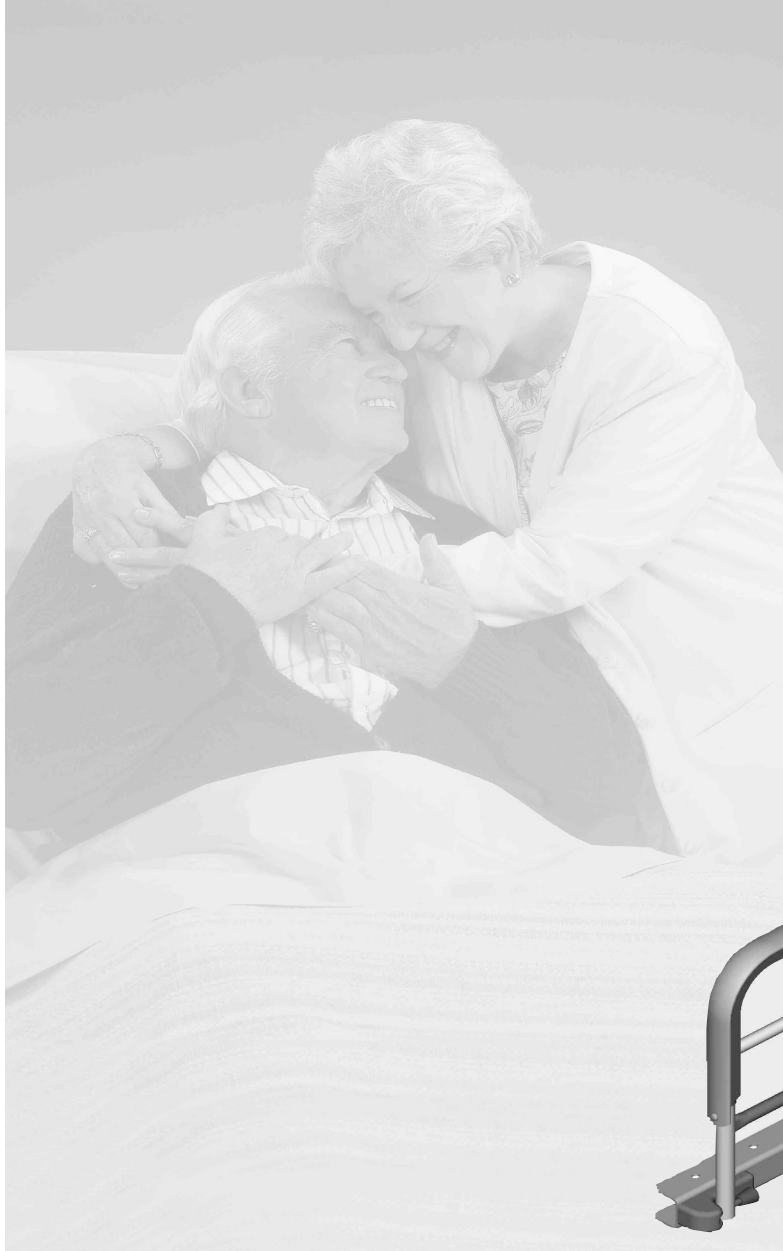

leading bed evolution

## Important Precautions

**⚠ Warning: Risk Of Serious Injury Or Death.** This product is intended for use with the Joerns U770, U790, U795 and UCXT beds. Use of this product on any bed it was not designed for could result in an unproven or unsafe configuration, potentially resulting in serious injury or death. For questions regarding compatibility, contact your Joerns Healthcare Representative.

**⚠ Warning: Risk Of Serious Injury Or Death.** Use a properly sized mattress in order to minimize the gap between the side of the mattress and the assist device. This gap must be small enough to prevent a resident from getting his/her head or neck caught in this location. Make sure that raising or lowering the bed, or articulating the sleep surface does not create hazardous gaps. Failure to do so could result in serious injury or death.

**⚠ Warning: Risk Of Serious Injury Or Death.** Properly locate the mounting brackets for the assist device. The gap between the head/foot panel and the assist device must be large enough to prevent a resident from getting his/her head or neck caught in this location (see the installation instructions for more information). If multiple assist devices are needed, position them such that the gap between them is large enough for the trunk and hips to easily pass through. Make sure that raising or lowering the bed, or articulating the sleep surface does not create hazardous gaps. Failure to do so could result in serious injury or death.

**⚠ Warning: Risk Of Serious Injury Or Death.** Do not use this assist device if any openings within the assist device body will allow a resident to get his or her head or neck lodged within these openings. Failure to do so could result in serious injury or death.

**⚠ Warning: Risk Of Serious Injury Or Death.** Do not use this assist device until you have verified that it is locked in place. Injury to resident or caregiver may result if this procedure is not followed.

**⚠ Warning:** An optimal bed system assessment should be conducted on each resident by a qualified clinician or medical provider to ensure maximum safety of the resident. The assessment should be conducted within the context of, and in compliance with, the state and federal guidelines related to the use of restraints and bed system entrapment guidance, including the Clinical Guidance for the Assessment and Implementation of Side Rails published by the Hospital Bed Safety Workgroup of the U.S. Food and Drug Administration. Further information can be obtained at the following web address: <http://www.fda.gov/MedicalDevices/ProductsandMedicalProcedures/GeneralHospitalDevicesandSupplies/HospitalBeds/default.htm>.

**⚠ Warning:** In the event worn or broken part(s) are identified, remove the device from service until repairs are made.

**Note:** The assist device is intended for use as an aid in entering or exiting the bed sleep area, as well as a stable handhold during self positioning within the bed sleep area.

This assist device is only one part of your healthcare bed system. Proper combinations of bed, mattress, head/foot panels, and assist devices are needed to minimize the risk of entrapment. For more information, contact your Joerns representative.



**Bed System Entrapment Information**

In April 1999, the U.S. Food and Drug Administration (FDA) in partnership with representatives from the hospital and post-acute bed industry, including Joerns Healthcare, national healthcare organizations, resident advocacy groups, and other federal agencies formed the Hospital Bed Safety Workgroup (HBSW). The workgroup’s goal is to improve the safety of bed frames for residents and patients in all health care settings who are most vulnerable to the risk of entrapment. The efforts of the FDA and the HBSW culminated in the FDA’s release of recommended guidelines intended to reduce the risk of entrapment, including dimensional limits for critical gaps and spaces between bed system components and clinical guidance for assessment and implementation of bed side rails in various health care settings.

Entrapment zones involve the relationship of bed components often directly assembled by the healthcare facility rather than the manufacturer. Therefore, compliance is the responsibility of the facility.

As the leading manufacturer of long-term care beds and a frontrunner in addressing this critical issue, Joerns Healthcare can offer you the expertise, assistance and products to bring your facility into compliance.

**Joerns® Compliance Solutions**

Matching the right bed components in order to meet regulatory guidelines can be complex.

That is why Joerns offers a wide array of compliance options. We assist customers in selecting compliant accessories recommended for their specific bed model.

**Creating a Safer Care Environment**

While the guidelines apply to all healthcare settings, hospitals, nursing homes and at home, long-term care facilities have particular exposure since serious entrapment events typically involve frail, elderly or dementia patients.

**For More Information**

To learn more about compliance options with Joerns products, visit our website at [www.joerns.com](http://www.joerns.com), or contact our Customer Care reps (800-826-0270) and ask for free informational publications.

To learn more about entrapment zones, assessment methods, and guidelines concerning entrapment, contact Joerns Healthcare (800-826-0270) or consult the FDA website: <http://www.fda.gov/MedicalDevices/ProductsandMedicalProcedures/GeneralHospitalDevicesandSupplies/HospitalBeds/default.htm>.

**Table of Contents**

Important Precautions ..... 2

Entrapment Information ..... 3

Assist Handle Installation Instructions ..... 4

Assist Handle Operation Instructions ..... 5

Warranty ..... 6

## F026 Assist Handle Installation Instructions

*Suggested Tools: 1/2" Socket Wrench, 3/8" Torque Wrench, 9/16" Socket*

Parts List		
Item	Description	Qty
1	Assist Handle PN: 31008850	1
2	Mounting Channel PN: 31008848	1
3	5/16"-18 Bolt PN: 12523751	2
4	Lock Nuts 5/16"-18 Hex PN: 12673107	2
5	Nut Retainers PN: 11013270	2
Service Parts		
6	Latch PN: 11012007	2
7	Latch Pin Kit PN: 39000820	1

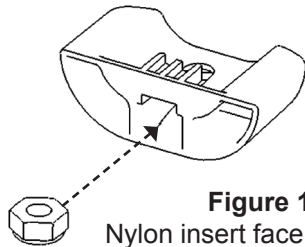

**Figure 1**

Nylon insert face down

1. Determine where you want the assist handle to be mounted (Figure 2).
2. Orient the mounting channel (Item 2) with the bed as shown in Figure 3 on page 5.
3. When mounting to an 80" head section, line up holes A & E and holes B & G. For a 76" head section, line up holes A & E and holes B & F. The mounting bracket is attached to the foot section on either 76" or 80" beds using holes C & H and holes I & D (Figure 2). Please note the same mounting bracket is used in all mounting locations listed above.
4. Insert nuts into nut retainers (Figure 1).
5. Insert 5/16" bolts (Item 3) through holes of mounting channel and holes on sleep surface (Figure 3 on page 5) and fasten securely with 5/16" nuts in retainers (Item 4).

**Maintenance/Inspection Information:** Visually inspect the assist handle and mounting bracket, and check for loose hardware on a monthly basis. Tighten loose hardware as stated in the installation instructions.

**Warning:** In the event worn or broken part(s) are identified, remove the device from service until repairs are made.

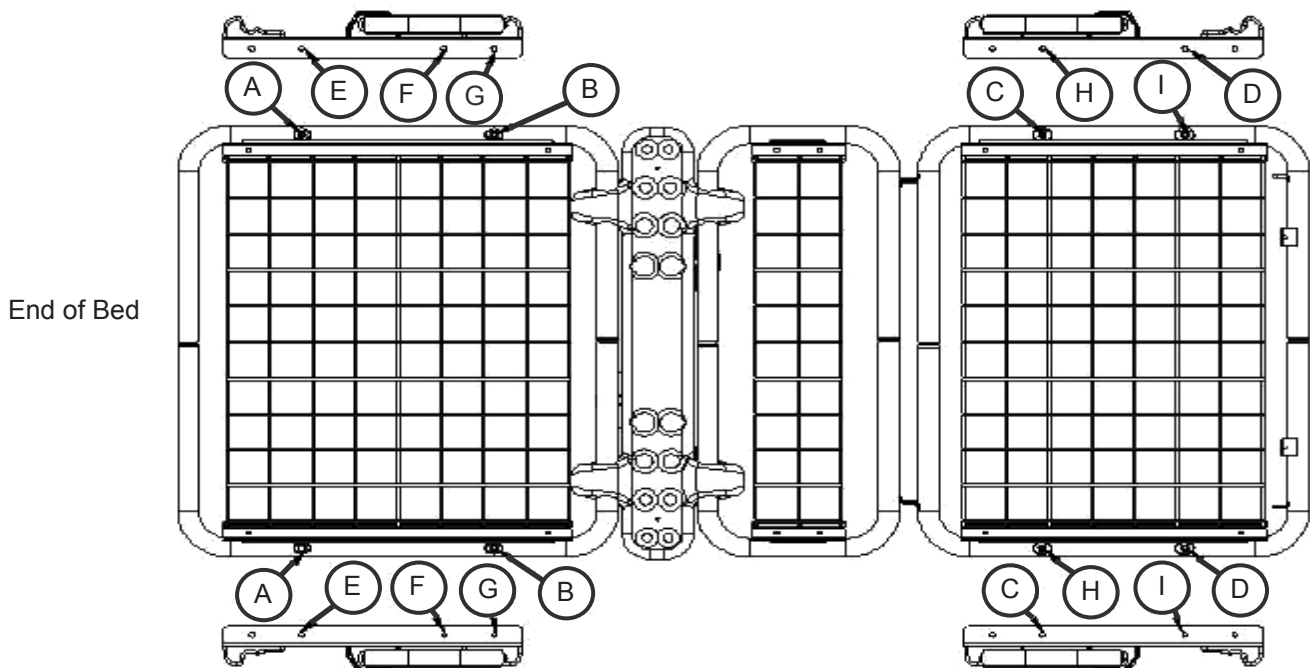

**Figure 2**

# F026 Assist Handle Operation Instructions

1. Insert the assist handle into the mounting bracket as shown in Figure 4. The assist handle must be perpendicular to the sleep surface.

**Note:** Insert the bushing completely into the mounting bracket until the flange is resting upon the bracket. Failure to ensure proper installation may lead to damage to the bushing, a reduced product life, and/or poor function of the assembly.

2. After the assist handle is inserted, it can be rotated 90 degrees towards the head or foot section of the bed.
3. Lock the assist handle by engaging the latch pin into the latch (Item 6) as shown in Figure 5.
4. Verify that the assist handle is locked prior to leaving any resident unattended.
5. To remove the assist handle: orient the assist handle perpendicular to the sleep surface as shown in Figure 6. Pull straight up on the assist handle to remove.

**Warning:** In the event worn or broken part(s) are identified, remove the device from service until repairs are made.

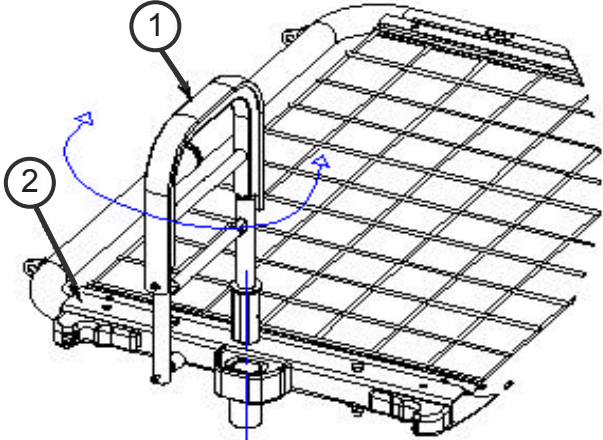

Figure 4

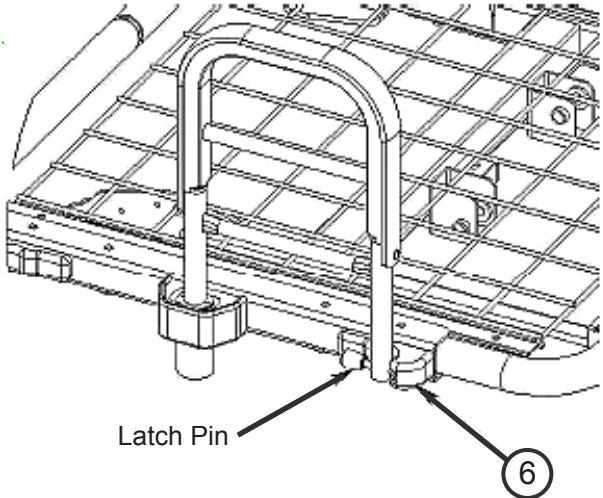

Figure 5

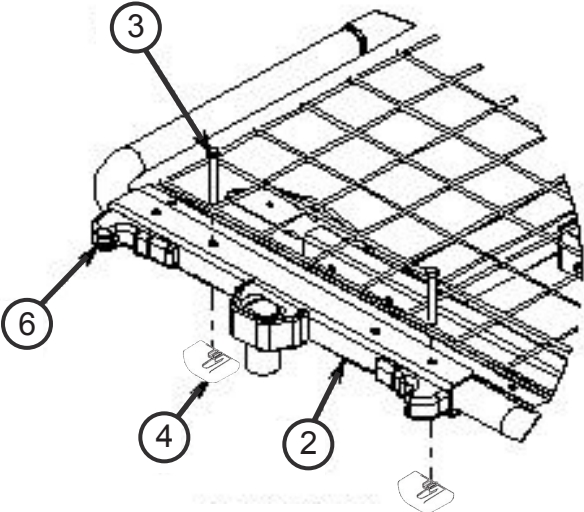

Figure 3

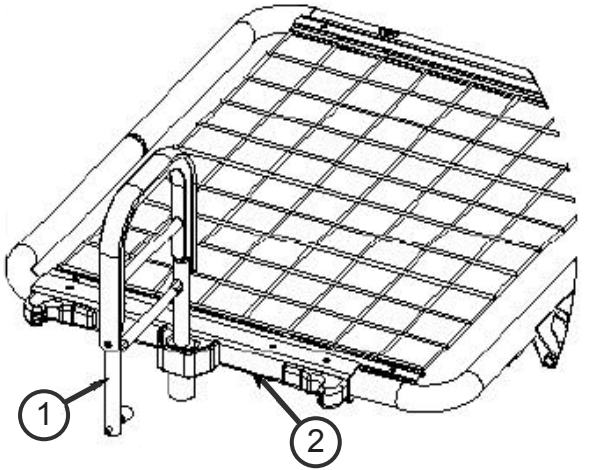

Figure 6

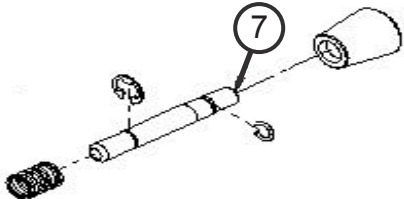

Figure 7 - Kit, Latch Pin (Includes all parts shown)

## Joerns Healthcare Warranty Program

for all Joerns® Assist Devices and Side Rails

Joerns assist devices and side rails are guaranteed for a period of 12 months from the date of delivery against defects in materials and workmanship under normal use and service.

Steel structural components and welds are covered under warranty for a period of ten years from the date of delivery.

This warranty does not apply to damage or defects caused by misuse, incorrect handling or installation by a non-authorized installer. Damage caused by use in unsuitable environmental conditions or failure to maintain the product in accordance with user and service instructions is not covered. Any alteration, modification or repair unless performed by or authorized in writing by Joerns Healthcare will void this warranty.

The product contains various parts that wear from normal use. These parts, such as plastic bushings, are not covered under the 12-month warranty, but are covered for 90 days after purchase of product.

Joerns Healthcare's obligation under this warranty is limited to supplying replacement parts, servicing or replacing, at its option, any product which is found by Joerns Healthcare to be defective.

Warranty replacement parts are covered by the terms of this warranty until the product's original warranty period expires.

When requested by Joerns Healthcare, parts must be returned for inspection at the customer's expense. Credit will be issued only after inspection.

### Service

Most service requests can be handled by the facility Maintenance Department with assistance from the Joerns Healthcare product Service Department. Most parts requested can be shipped UPS next day air at the customer's expense. Should a technician be required, at our discretion, one will be provided by Joerns Healthcare. Only the Joerns Healthcare Product Service Department can dispatch authorized technicians. For prompt warranty inspection and service contact your local authorized representative or Joerns Healthcare Customer Service at 800.826.0270

